

PROGETTO

APHRODITE

PERFUME IS THE KEY TO OUR MEMORY



LABORATORIO DI GRAFICA
PACKAGING AND ADVERTISING EXPERIENCE
Classe 5^aC Grafica a.s. 2019_2020

Il progetto APHRODITE è una esercitazione didattica volta ad approfondire le conoscenze ed esperienze del mondo della comunicazione.

Il PROFUMO è il tema di questo lavoro.

Profumo per la donna e anche per l'uomo. Un tema molto stimolante che ci trascina in nuove emozioni. Quelle stesse emozioni, da vivere a occhi chiusi, che trasmettono le fragranze e anche il semplice rapporto tattile con il contenitore e con la pressione del dito sull'erogatore.

MANUALE OPERATIVO
MARCHIO STILISTA

AZÜL

PERCHÉ IL NOME “AZÙL”?

Il termine Azùl significa ‘azzurro’ in varie lingue del mondo. Nello specifico, la scelta di questo nome deriva dall’esistenza di una pietra di rara bellezza, che appartiene alla famiglia delle quartziti, detta “Azùl Macaubas”. Essa, si trova solo in una parte del mondo, a ovest della città di Macaubas nello stato di Bahia.

Il marmo Azul Macaubas offre splendide tonalità che combinano l'azzurro, il bianco e il blu, dai più delicati toni a quelli più profondi e affascinanti.

Caratterizzato da una grande durezza e durabilità, il marmo Azul Macaubas viene impiegato in ogni tipo di realizzazione, dal pavimento di eleganti bagni al top di moderne cucine, da oggetti decorativi destinati all'uso domestico a sorprendenti rivestimenti di pregio per piscine, colonne e splendidi mosaici.

AZÙL

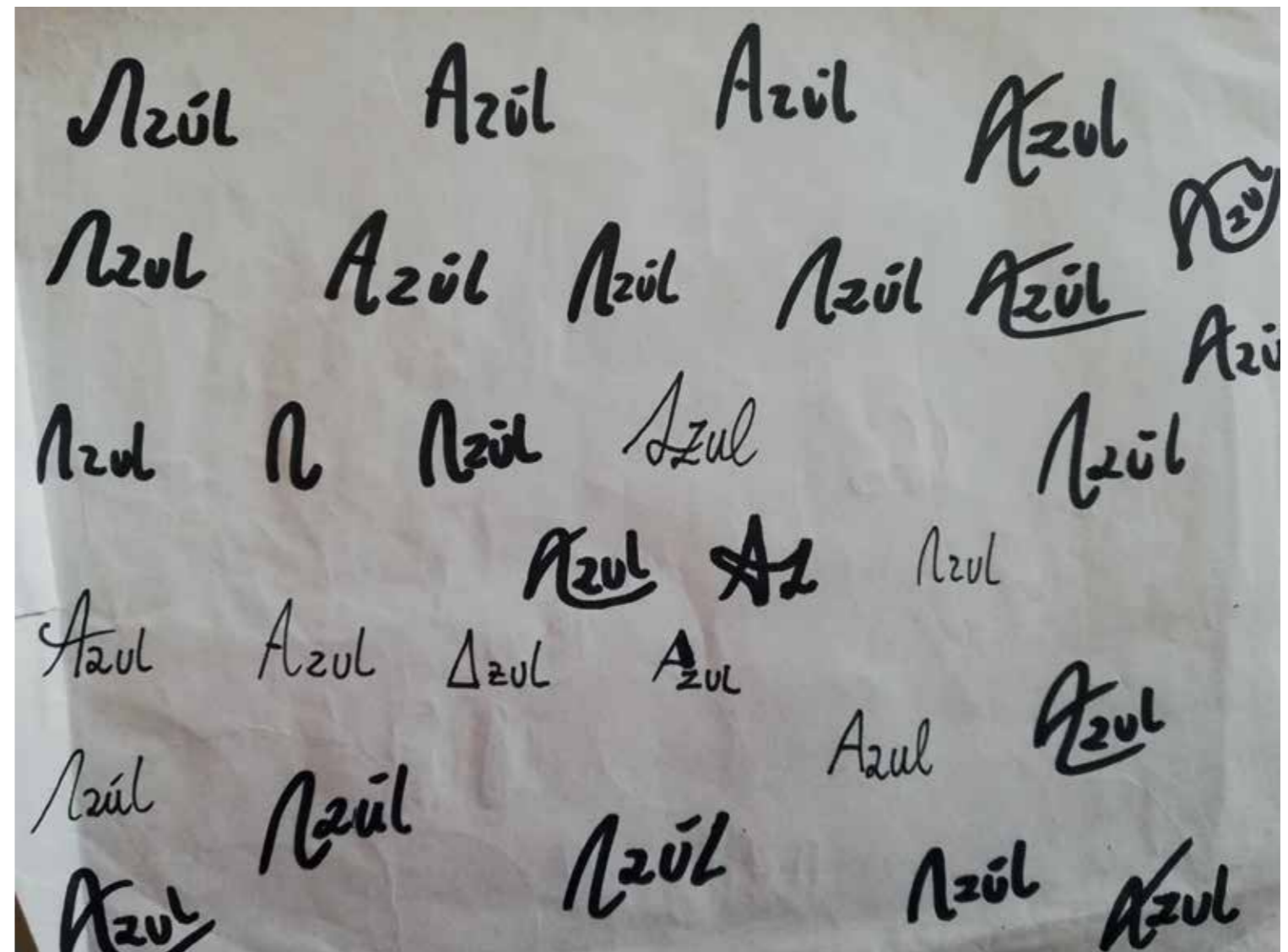

AZÜL

H: 179° S: 0% B: 99%
R: 252 G: 254 B: 254
C: 0% M: 0% Y: 0% K: 0%
#:FCFEFE

AZÜL

H: 240° S: 1% B: 0%
R: 0 G: 0 B: 0
C: 75% M: 68% Y: 66% K: 87%
#:000000

AZÜL 100%

AZÜL 75%

AZÜL 55%

AZÜL 25%

AZÜL 100%

AZÜL 75%

AZÜL 55%

AZÜL 25%

GABBIA



DISTANZA

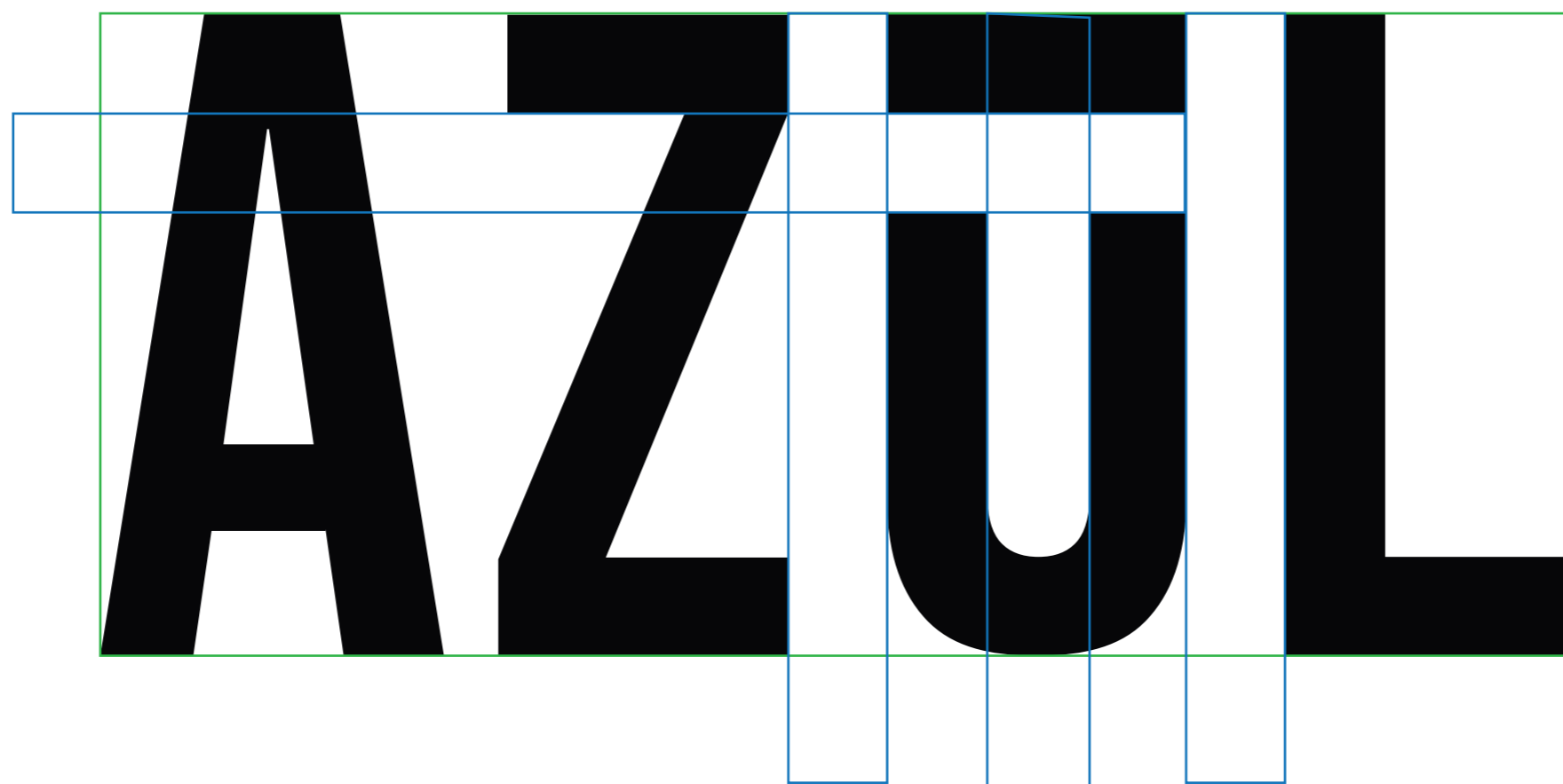

HEADING PRO TRIAL FONT

REGULAR

abcdefghijklmnopqrstwvzyxABCDEFGHIJLM
NOPQRSTUVWXYZI \!"£\$%&/()=^*°§

LIGHT

abcdefghijklmnopqrstwvzyxABCDEFGHIJLM
NOPQRSTUVWXYZI \!"£\$%&/()=^*°§

ITALIC

*abcdefghijklmnopqrstwvzyxABCDEFGHIJL
MNOPQRSTUVWXYZI \!"£\$%&/()=^*°§*

BOLD

**abcdefghijklmnopqrstwvzyxABCDEFGHIJ
LMNOPQRSTUVWXYZI \!"£\$%&/()=^*°§**

EXTRABOLD

**abcdefghijklmnopqrstwvzyxABCDEFGHI
JLMNOPQRSTUVWXYZI \!"£\$%&/()=^*°§**

HEAVY

**abcdefghijklmnopqrstwvzyxABCDEFGHI
IJKLMNOPQRSTUVWXYZI \!"£\$%&/()=^*°§**

LIGHT ITALIC

*abcdefghijklmnopqrstwvzyxABCDEFGHIJLM
NOPQRSTUVWXYZI \!"£\$%&/()=^*°§*

BOLD ITALIC

***abcdefghijklmnopqrstwvzyxABCDEFGHIJ
LMNOPQRSTUVWXYZI \!"£\$%&/()=^*°§***



H: 240° S: 1% B: 0%
R: 0 G: 0 B: 0
C: 75% M: 68% Y: 66% K: 87%
#:000000



AZÜL

non spostare o modificare tra loro
gli elementi del marchio



AZÜL

non deformare o distorcere il
marchio



AZÜL

non è consentito modificare il
colore del marchio



AZÜL

non è consentito aggiungere
effetti al marchio











IL NUOVO PROFUMO DI

AZŪL



PERCHÉ IL NOME “**BRAZIL**”?

La scelta di questo nome è strettamente legata al vasto paese sudamericano, il Brasile. La linea di profumi da uomo propone una fragranza fresca, tropicale e fine.

Il logo è formato da 8 quadrati separati, che opportunamente accostati formano la lettera B. I quadrati rappresentano le varie culture, arti ed etnie presenti in Brasile e l'unione tra loro.

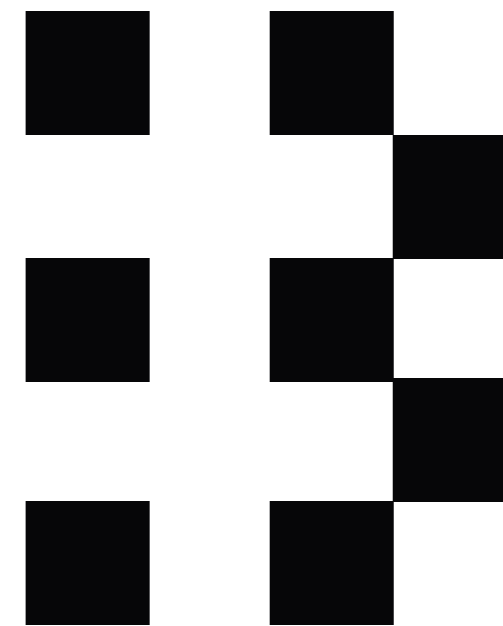

BRAZIL





**BRA
ZIL**

BRAZIL

B

BRAZIL

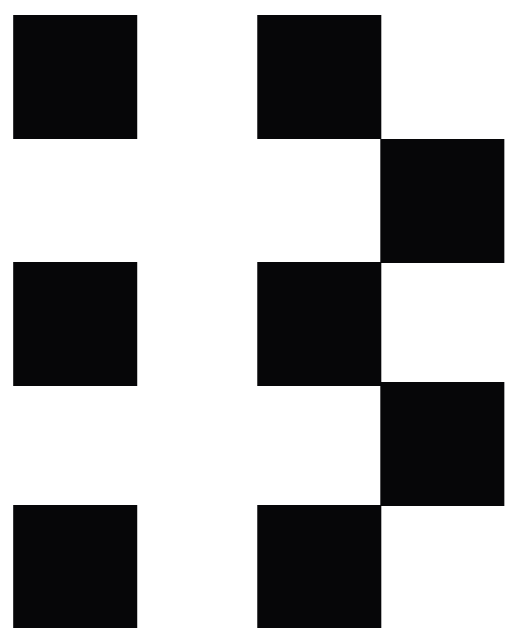

BRAZIL

H: 59° S: 0% B:100%
R: 255 G: 255 B: 255
C: 0% M: 0% Y: 0% K: 0%
#: FFFFFFFF



H: 59° S: 6% B: 11%
R: 29 G: 29 B: 27
C: 0% M: 0% Y: 0% K: 100%
#: 1D1D1B

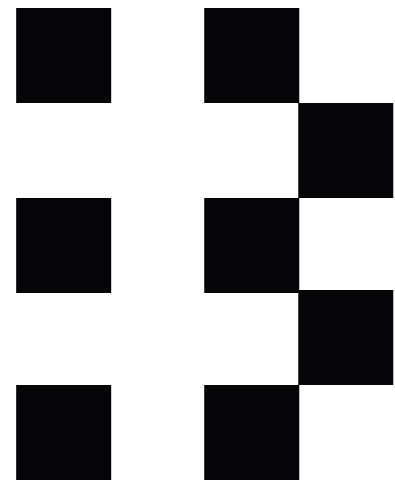

100%

BRAZIL

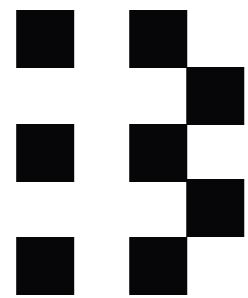

75%

BRAZIL

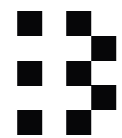

BRAZIL

35%

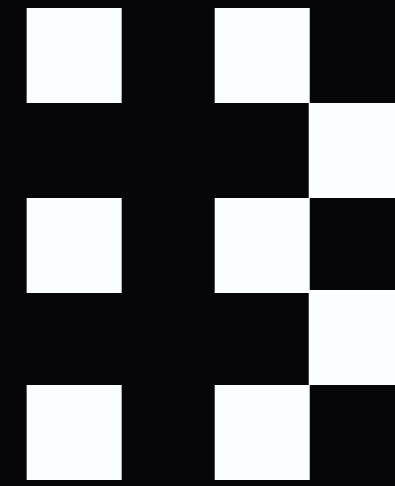

100%

BRAZIL

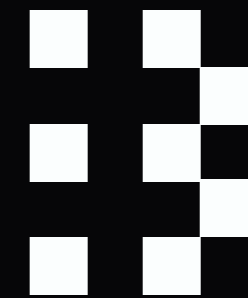

75%

BRAZIL



BRAZIL

35%

GABBIA

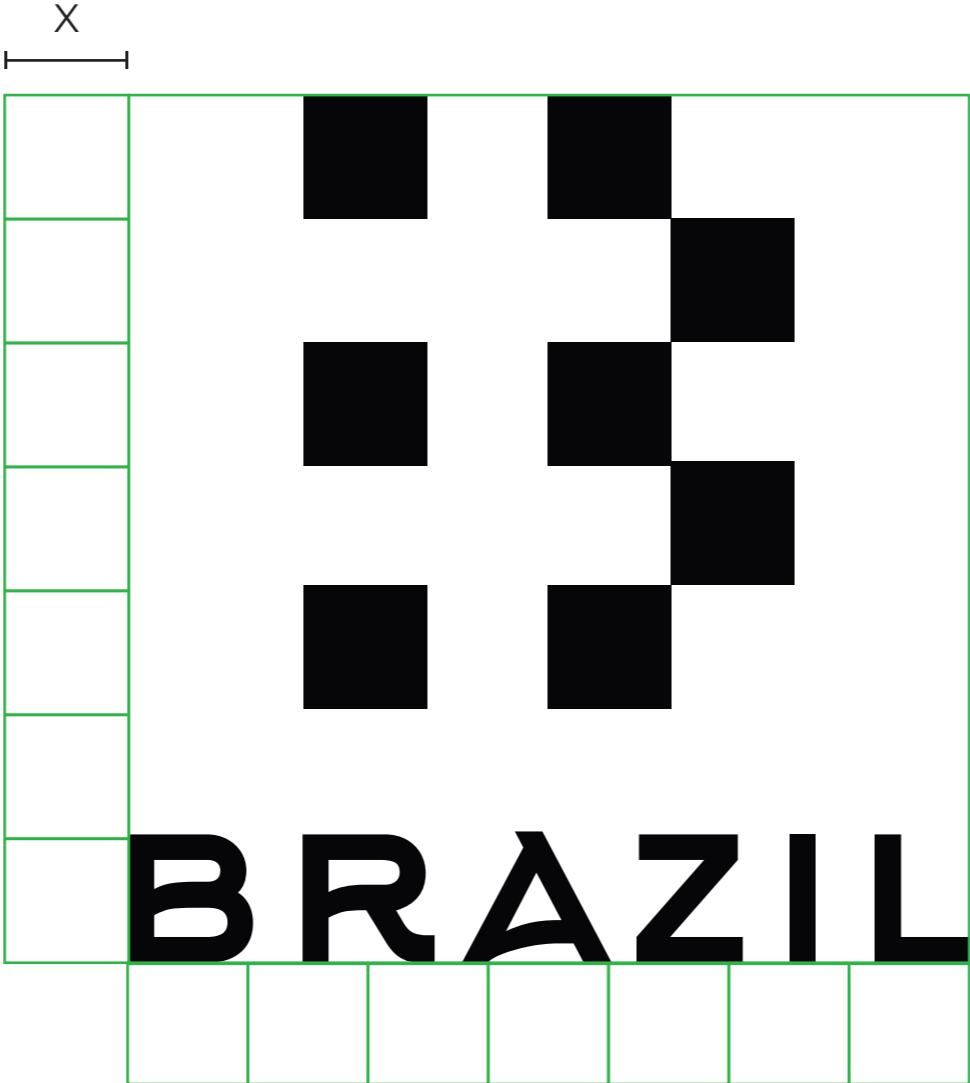

DISTANZA





H: 206° S: 31% B:30%
R: 54 G: 68 B: 79
C: 79% M: 64% Y: 50% K: 38%
#:36444F

ARKIP FONT

REGULAR

ABCDEFGHIJKLMNOJKPQRSTU-
vzyw123456789!"£\$%&/()="?"^

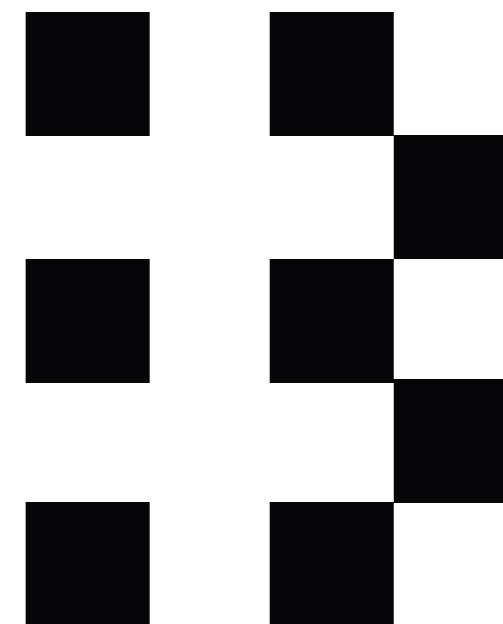

BRAZIL



H: 59° S: 0% B:100%
R: 255 G: 255 B: 255
C: 0% M: 0% Y: 0% K: 0%
#: FFFFFFFF



H: 0° S: 2% B: 0%
R: 0 G: 0 B: 0
C: 75% M: 68% Y: 66% K: 87%
#: 000000



H: 206° S: 64% B: 31%
R: 52 G: 68 B: 81
C: 79% M: 64% Y: 50% K: 38%
#: 344451



H: 0° S: 2% B: 0%
R: 0 G: 0 B: 0
C: 75% M: 68% Y: 66% K: 87%
#: 000000

L'etichetta è composta dal marchio e dal logotipo del profumo, posti in primo piano in alto. In basso abbiamo il logo dello stilista accompagnato da due fasce di colore giallo e verde che rappresentano la bandiera del Brasile.

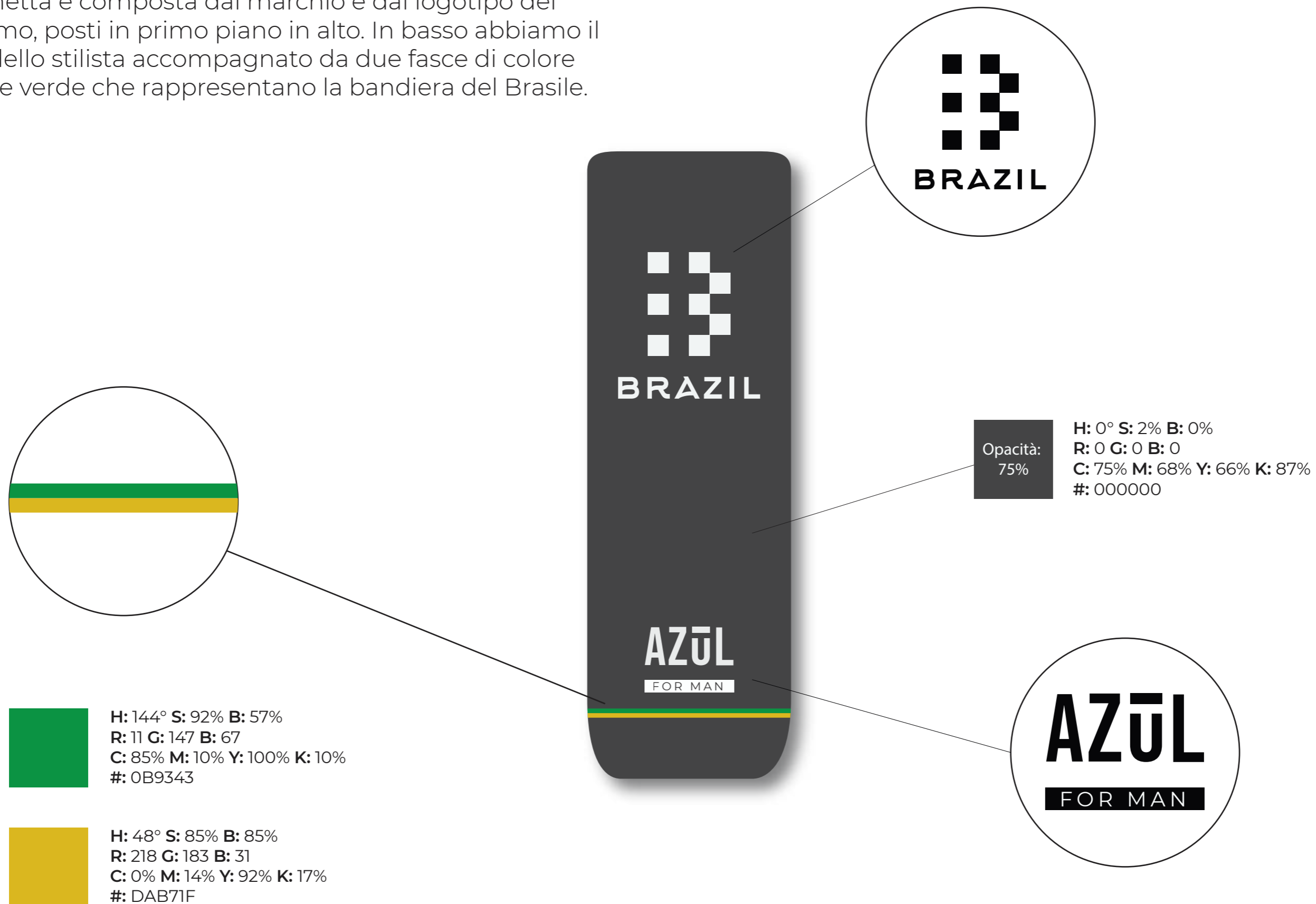

ETICHETTA E DIMENSIONI



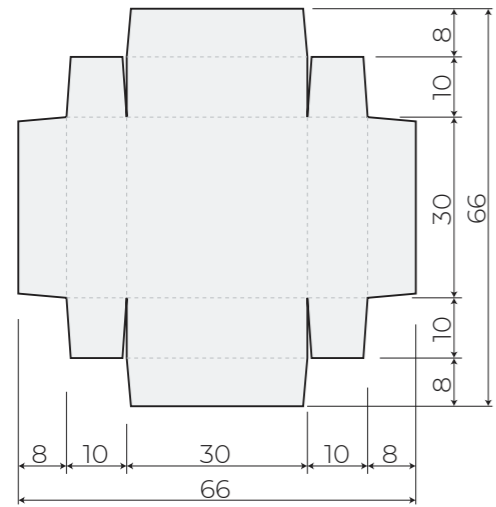

COMPONENTE N.1 - INCASSO BOTTIGLIA

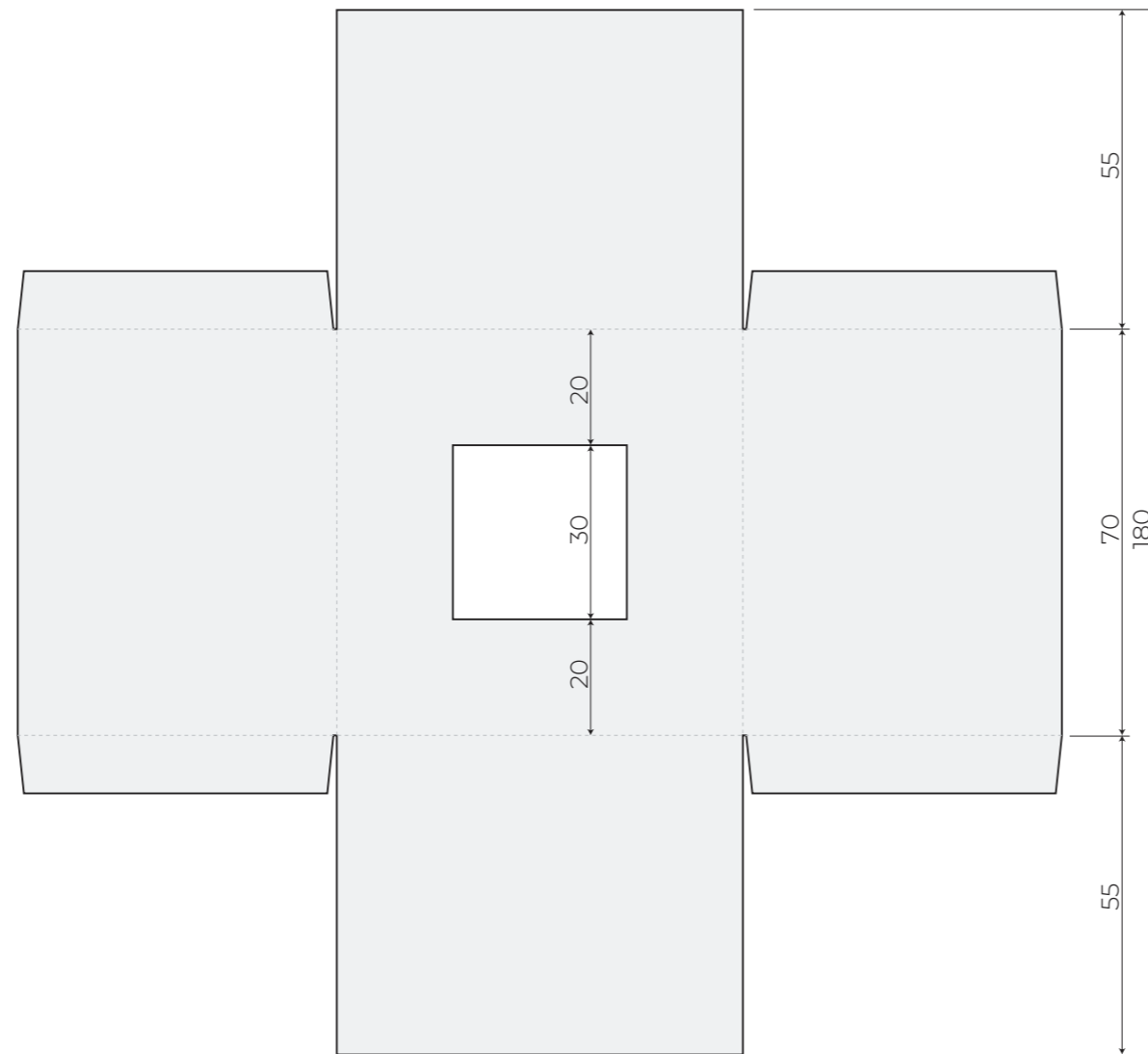
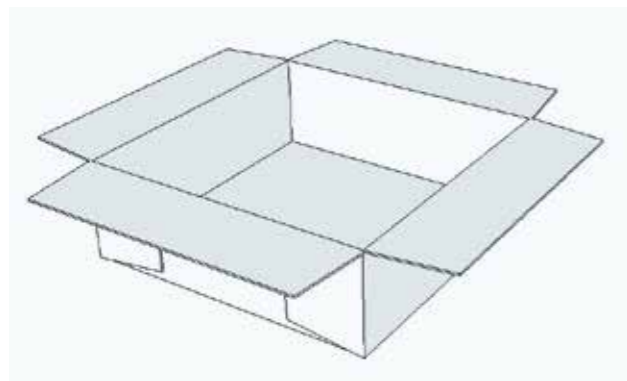

COMPONENTE N.2 - BASE INTERNA

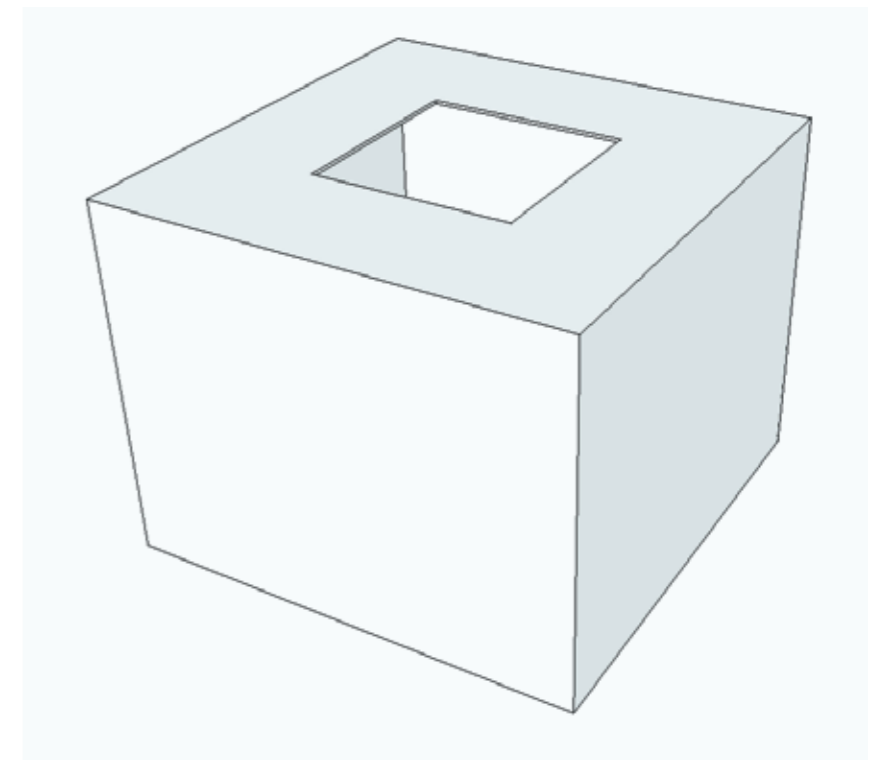

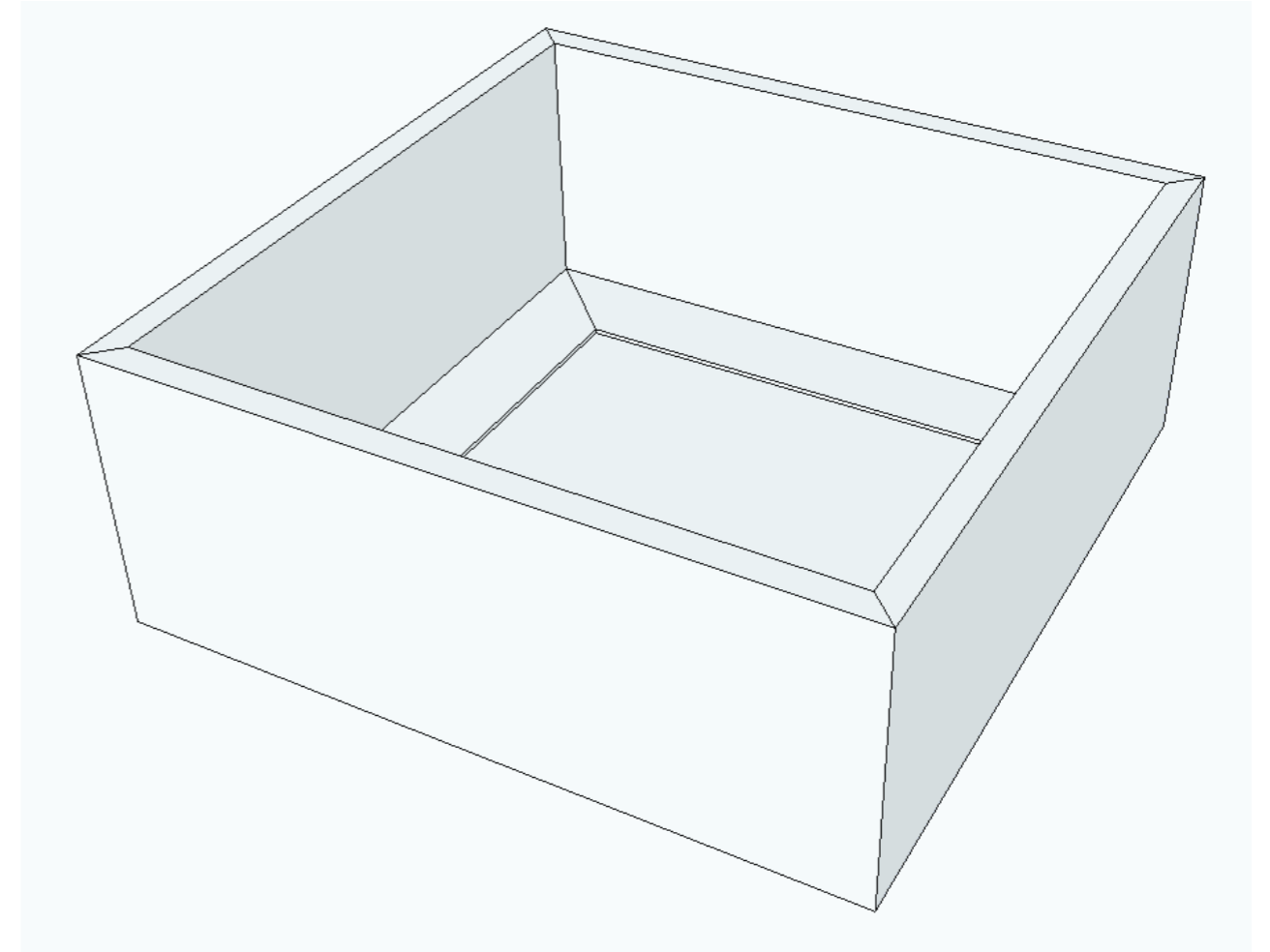
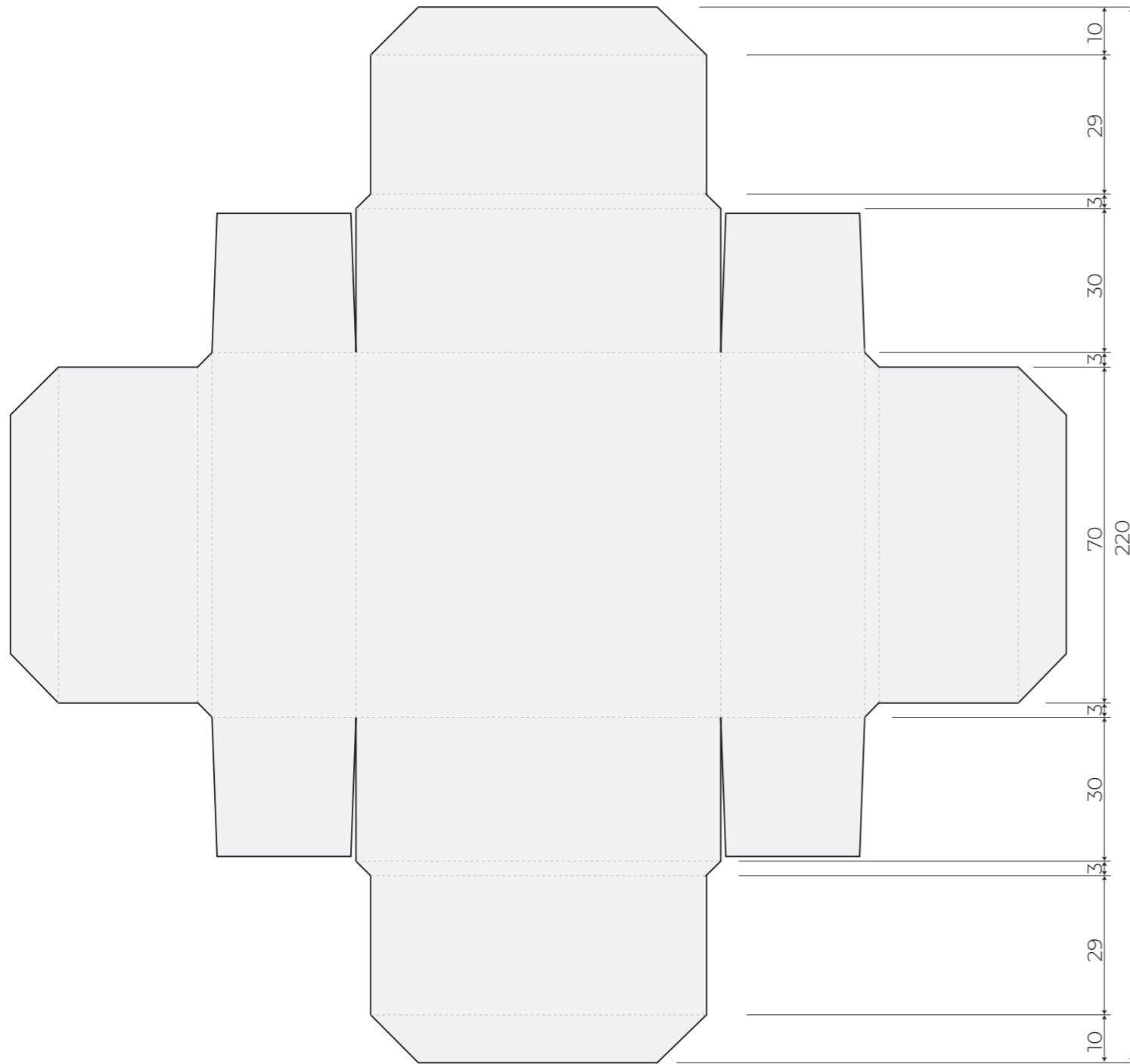

COMPONENTE N. 3 - BASE ESTERNA

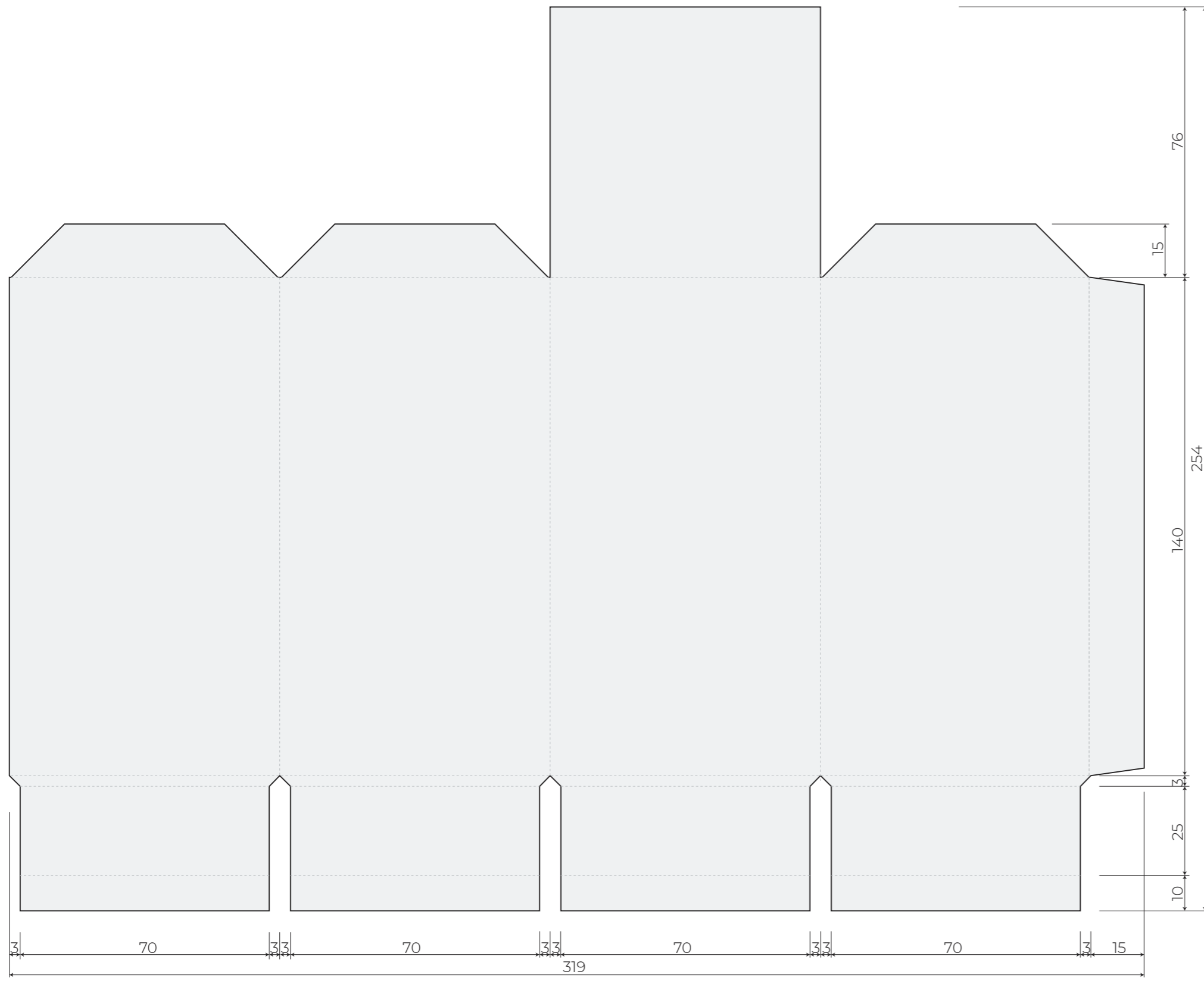

COMPONENTE N. 4 - COPERTURA SUPERIORE

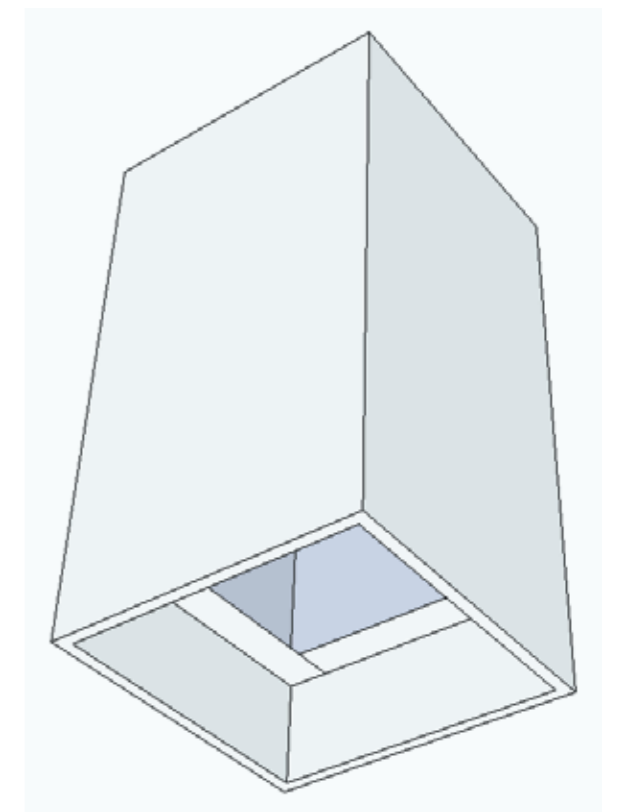
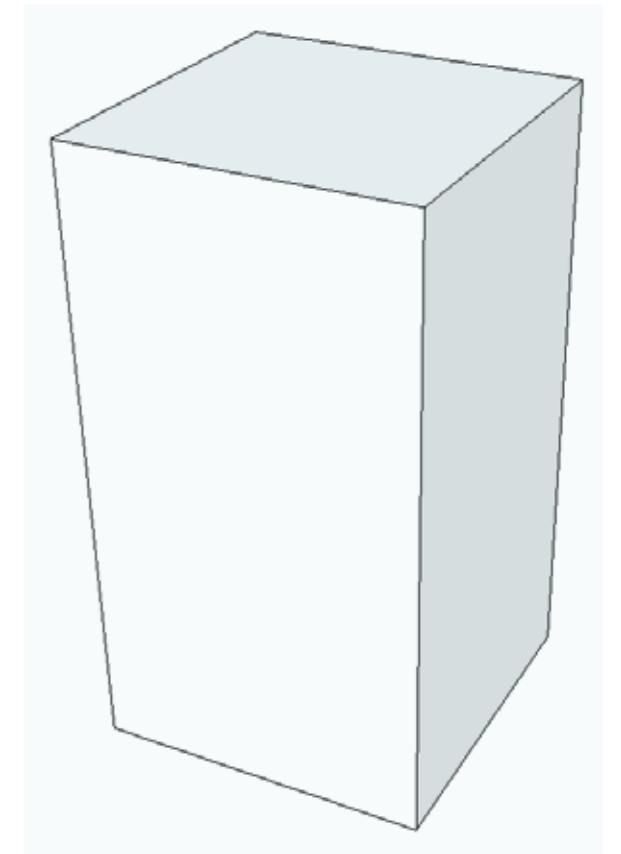

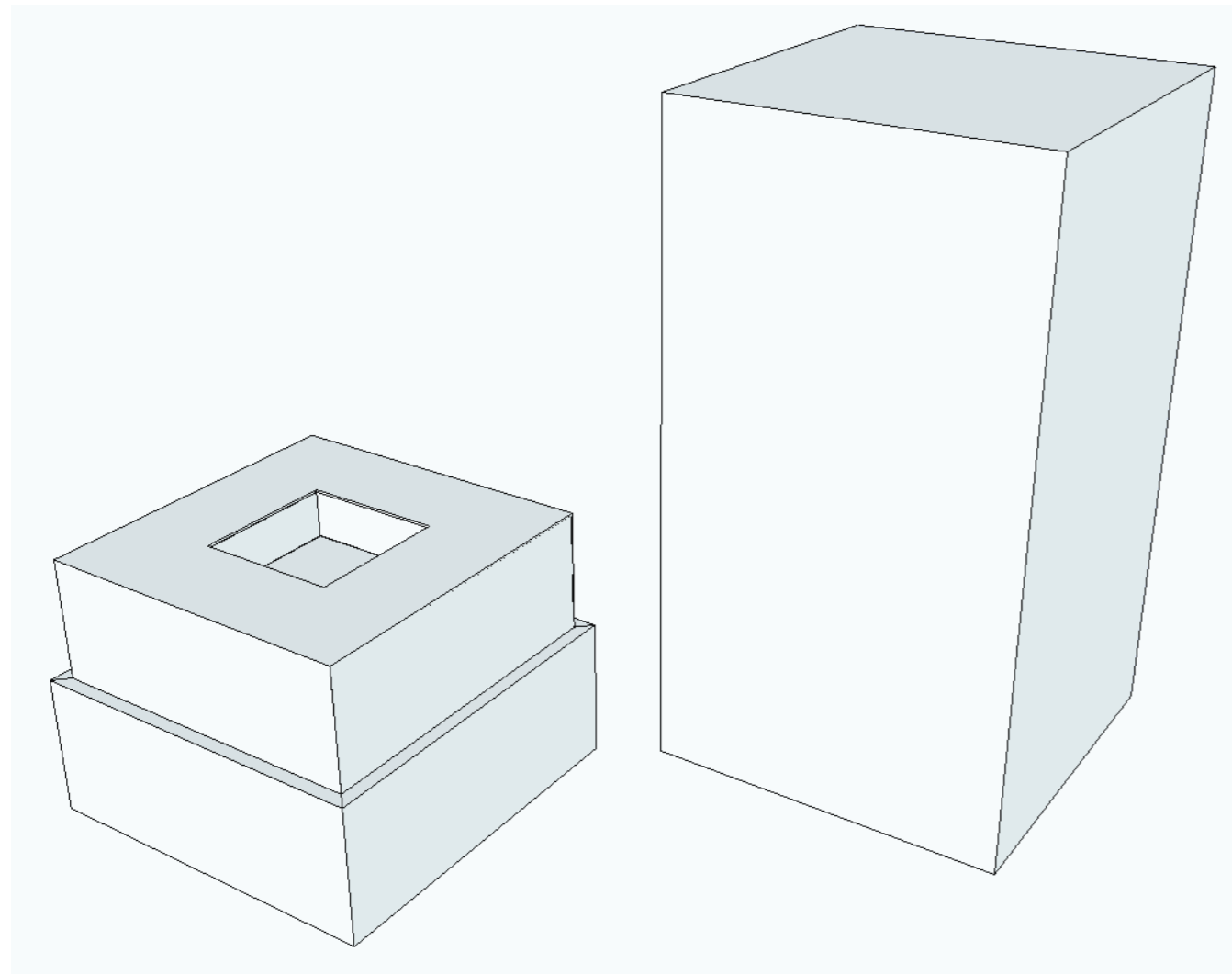

CONFEZIONE APERTA

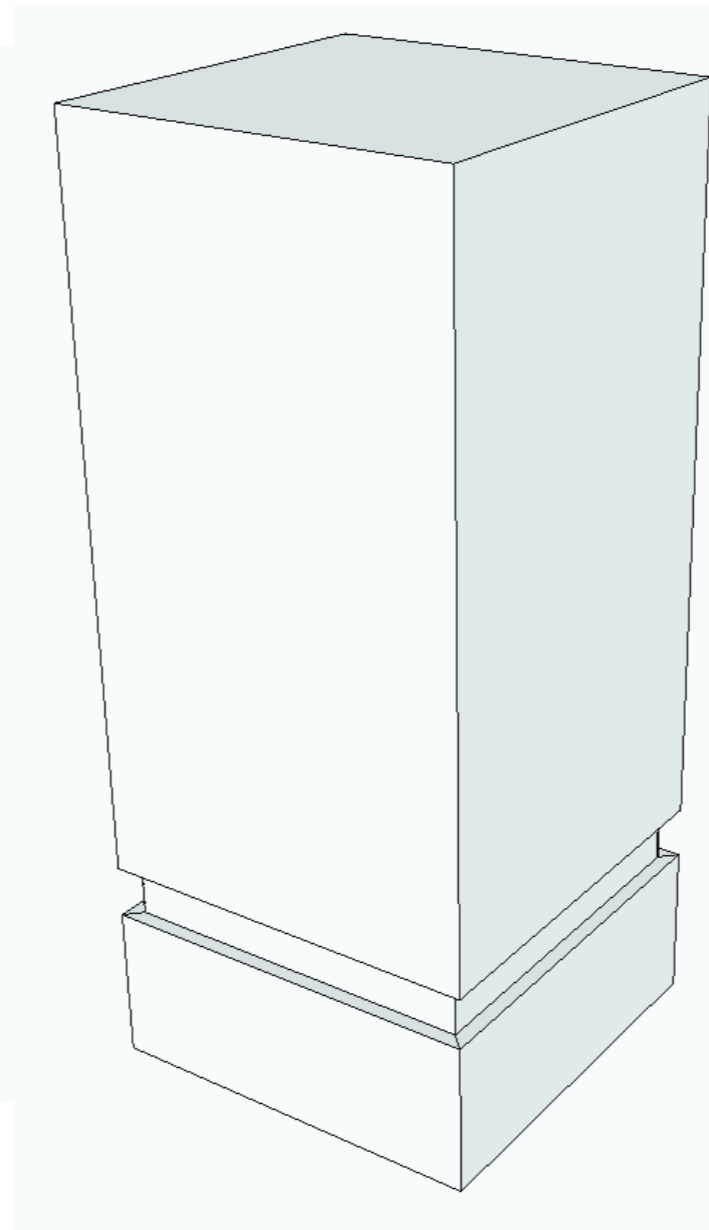

CONFEZIONE CHIUSA

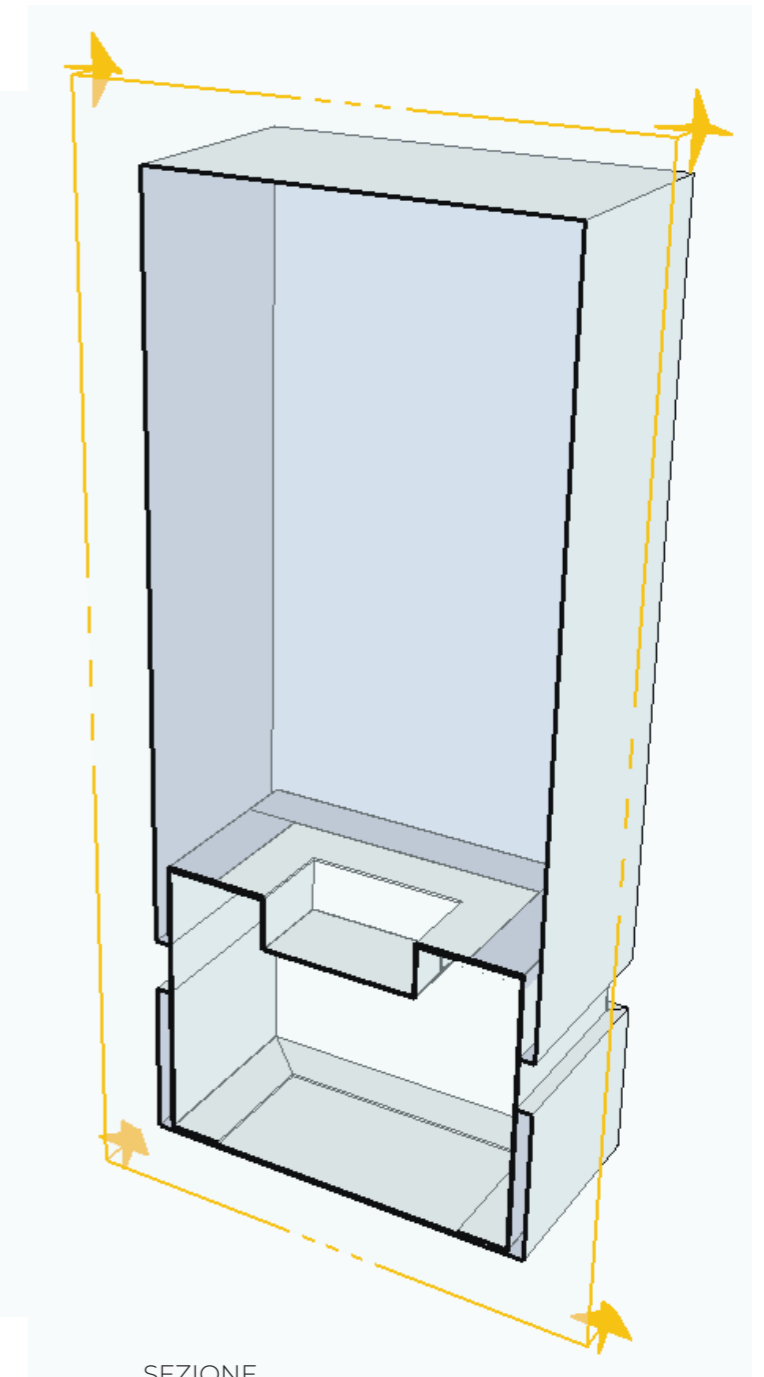

SEZIONE



COMPONENTE N. 2 - BASE INTERNA



COMPONENTE N. 3 - BASE ESTERNA

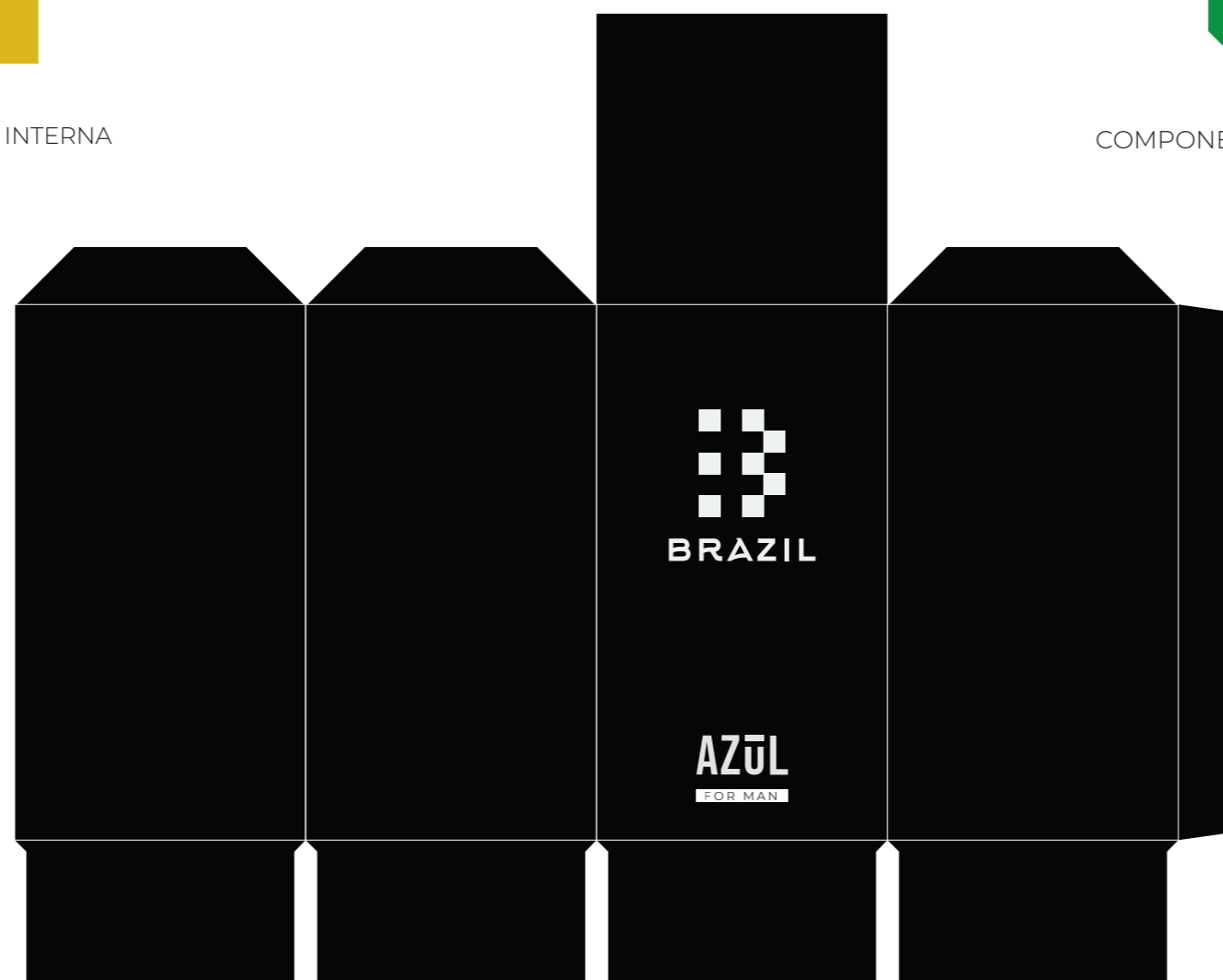

COMPONENTE N. 4 - COPERTURA SUPERIORE

La cura del packaging è proporzionale e coerente con la dimensione e l'etichetta del profumo. Infatti, ne riprende i colori e la forma. Presenta alla base i due colori giallo oro e verde, che simboleggiano la bandiera del Brasile.

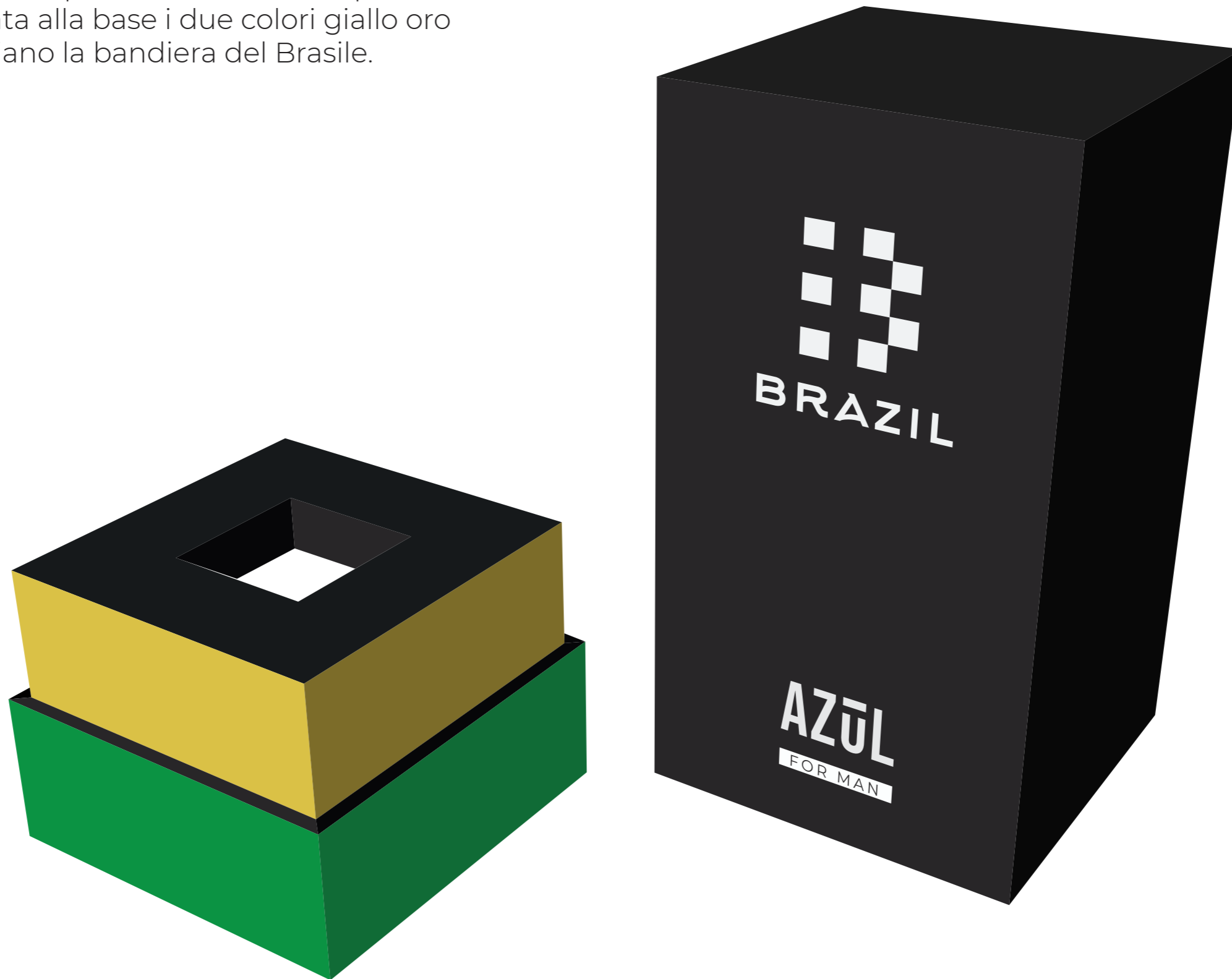

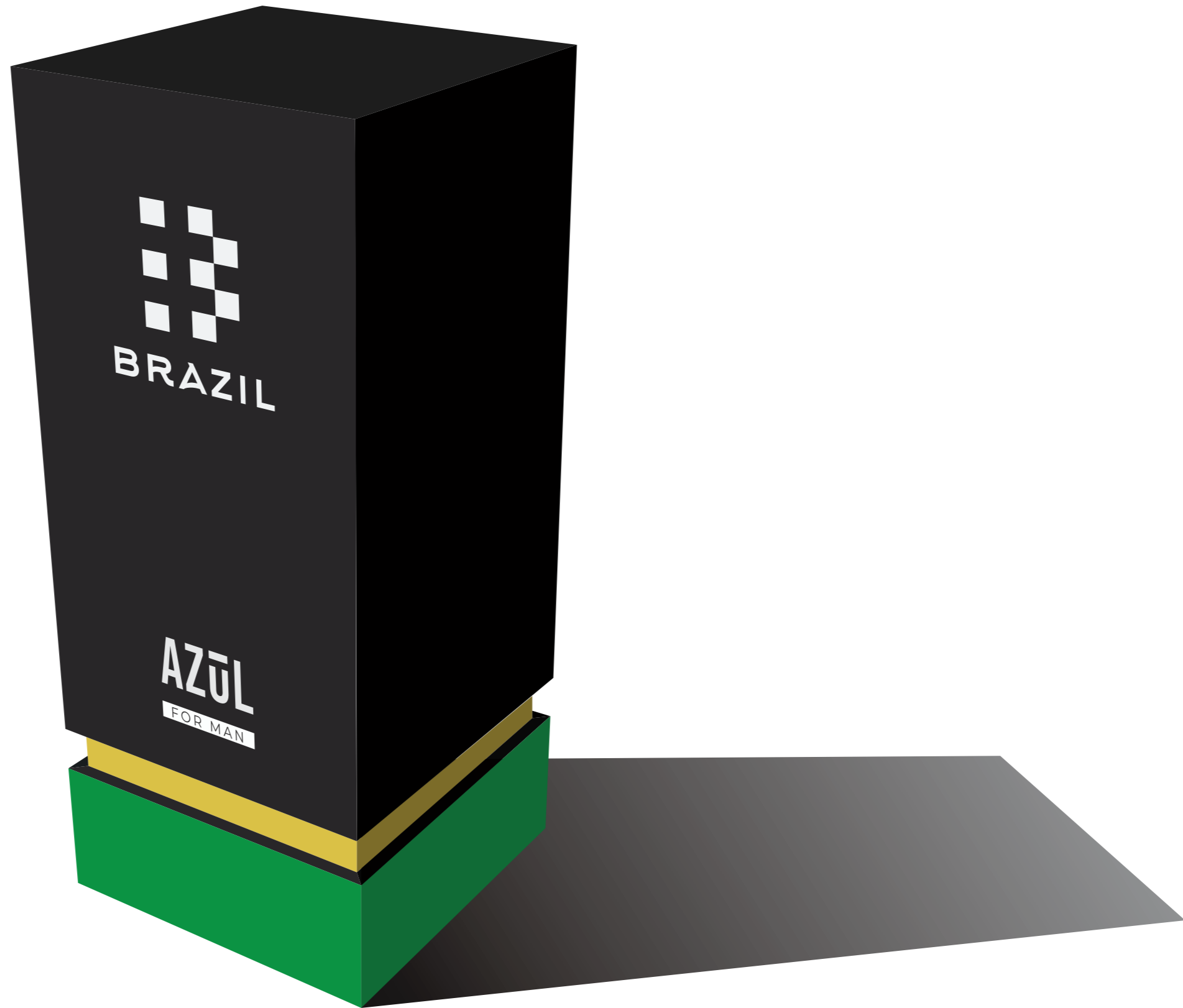





BRAZIL
BRAZIL EDITION
F O R M A N

AZUL

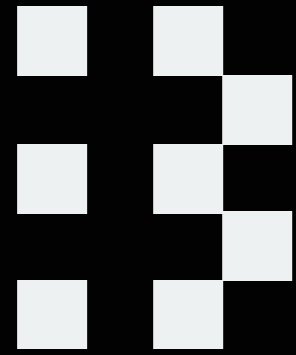

BRAZIL

BRAZIL EDITION

F O R M A N



AZUL



“NON SI È
MAI
COMPLETAMENTE
VESTITI SENZA
PROFUMO”



“NON SI È
MAI
COMPLETAMENTE
VESTITI SENZA
PROFUMO”













Lorem ipsum dolor
sit amet,



Lorem ipsum dolor
sit amet,



Lorem ipsum dolor
sit amet,



Lorem ipsum dolor
sit amet,



IL NUOVO PROFUMO DI AZUL

BRAZIL EDITION



IL NUOVO PROFUMO DI AZUL

BRAZIL EDITION

Lorem ipsum dolor sit amet, consectetur adipiscing elit, sed diam nonummy nibh euismod tincidunt ut laoreet dolore magna aliquam erat volutpat. Ut wisi enim ad minim veniam, quis nostrud exerci tation ullamcorper suscipit lobortis nisl ut aliquip ex ea commodo consequat. Duis autem vel eum iriure dolor in hendrerit in vulputate velit esse molestie consequat, vel illum dolore eu feugiat nulla facilisis at vero eros et accumsan et iusto odio dignissim qui blandit praesent luptatum zzril delenit augue dui dolore te feugait nulla facilisi.

Lorem ipsum dolor sit amet, consectetur adipiscing elit, sed diam nonummy nibh euismod tincidunt ut laoreet dolore magna aliquam erat volutpat. Ut wisi enim ad minim veniam, quis nostrud exerci tation ullamcorper suscipit lobortis nisl ut aliquip ex ea commodo consequat. Lorem ipsum dolor sit amet,



consectetur adipiscing elit, sed diam nonummy nibh euismod tincidunt ut laoreet dolore magna aliquam erat volutpat. Ut wisi enim ad minim veniam, quis nostrud exerci tation ullamcorper suscipit lobortis nisl ut aliquip ex ea commodo consequat. Duis autem vel



AZUL



“NON SI È
MAI
COMPLETAMENTE
VESTITI SENZA
PROFUMO”

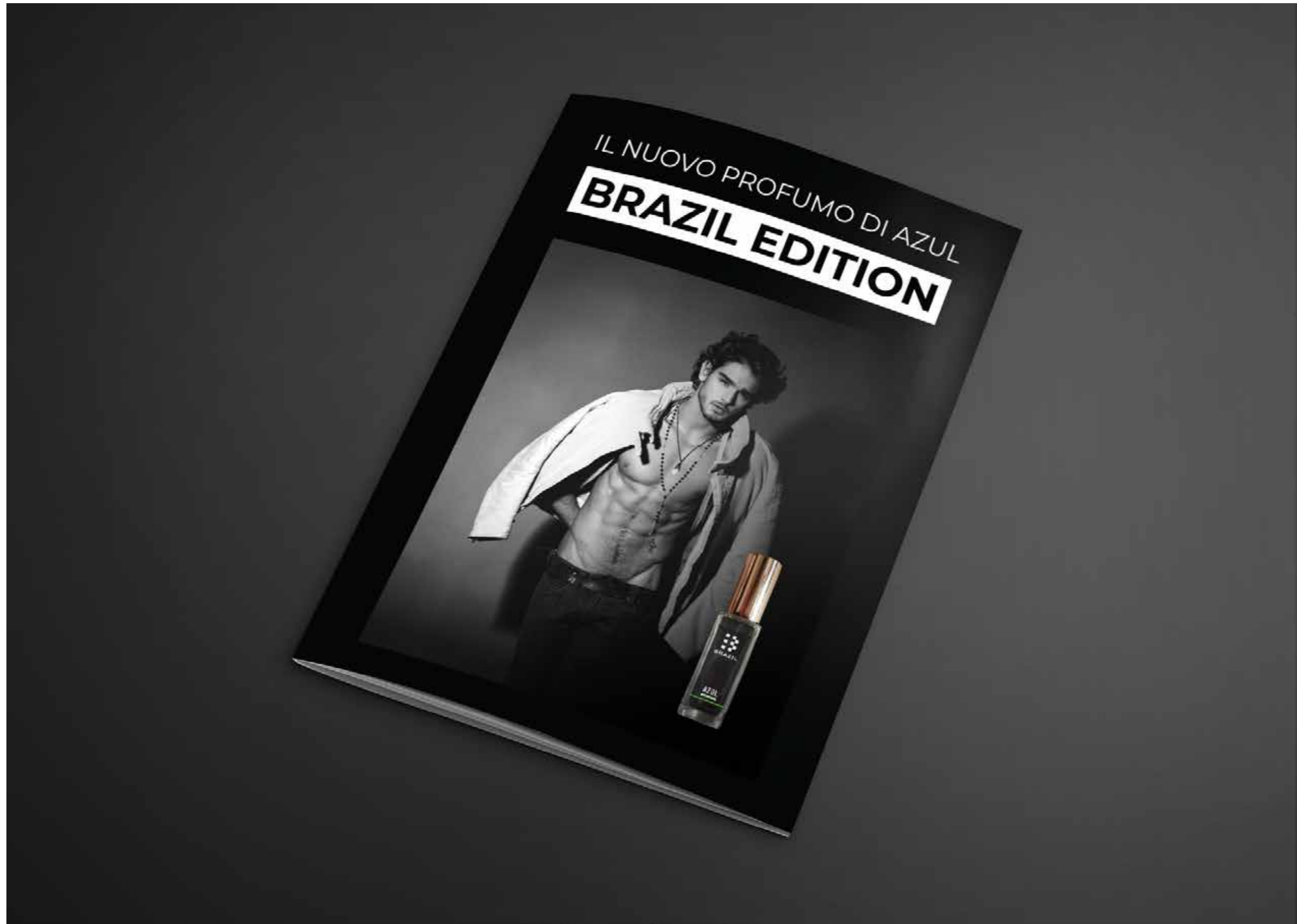





Graphic design: **Longo Azzurra**
classe 5^aC Grafica - a.s. 2019/20